

PRODUCT NUMBER	QUANTITY PER REEL	PACKAGING	REELING
73396-401	12500	CARDBOARD REEL	"A"
73396-401LF	12500	CARDBOARD REEL	"A"
73396-401RLF	12500	CARDBOARD REEL	"R"
73396-403LF	500	SMALL PLASTIC REEL	"P"

WHEN NEEDED, SUFFIX LETTER "LF" INDICATES THE PRODUCT IS RoHS COMPATIBLE, SEE NOTE

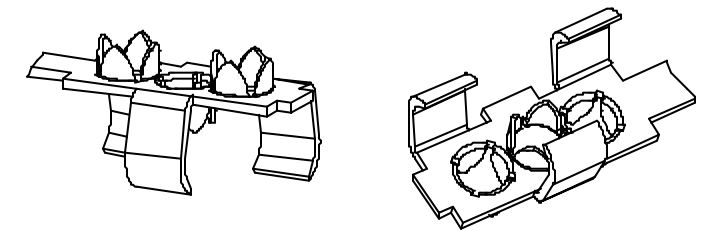
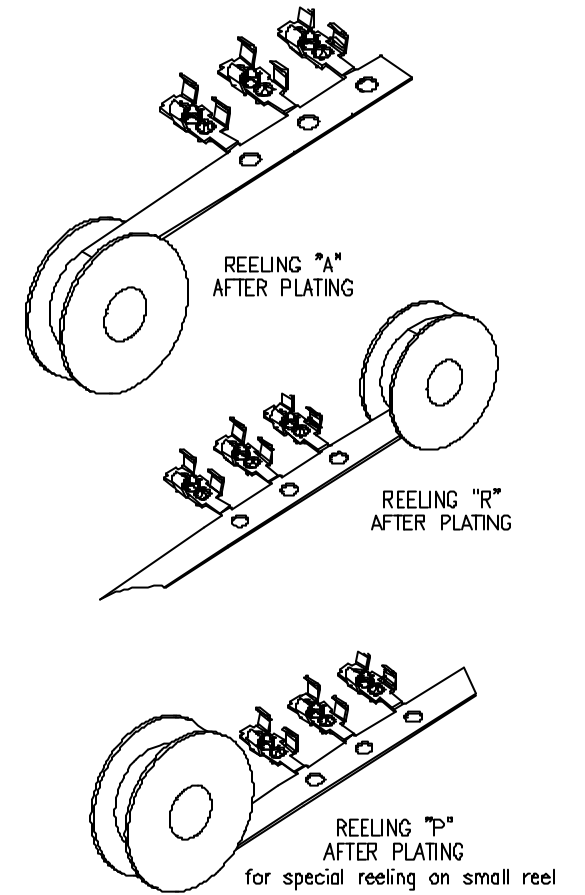
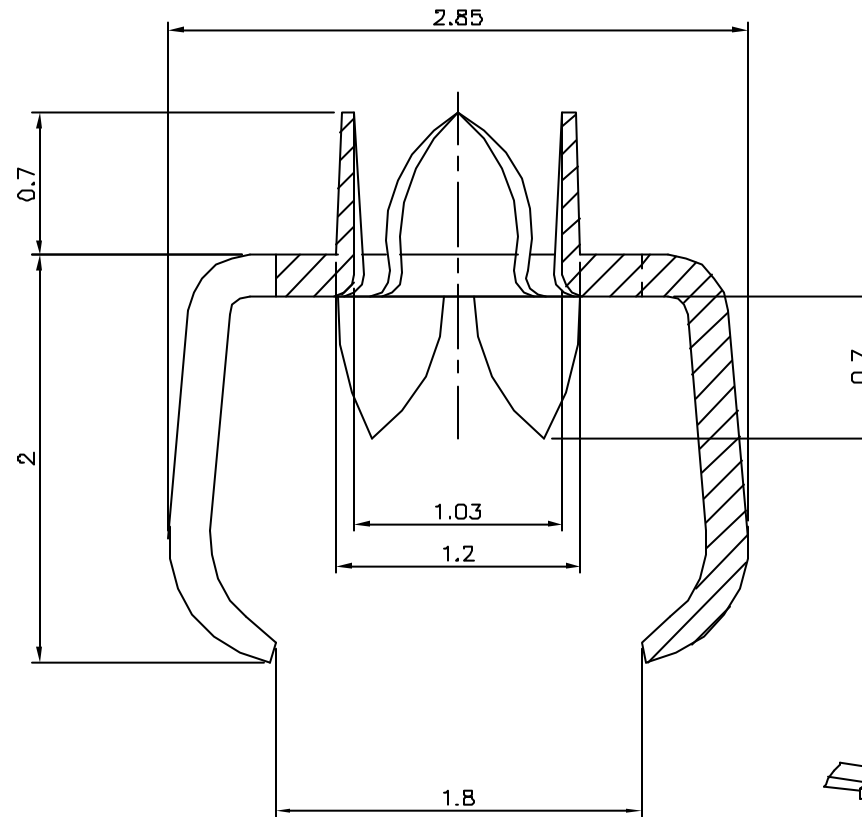
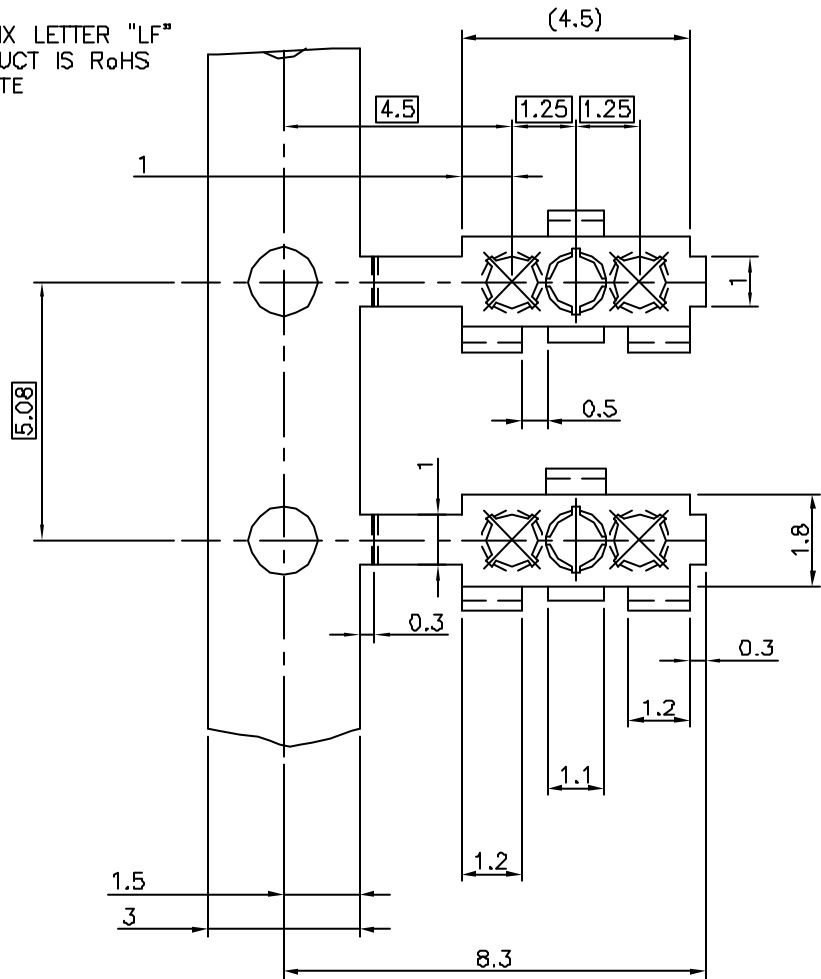

SCALE 40/1

NOTES

- 1 MATERIAL : PHOSPHOR BRONZE 3/4 HARD
- 2 PRODUCT IS POST PLATED
- 3 RoHS COMPATIBLE PRODUCT SPECIFICATIONS

a - PLATING:

- "LF" MEANS THE PRODUCT IS LEAD-FREE, 2µm MINIMUM MATTE TIN OVER 1.27µm MINIMUM NICKEL UNDERPLATE.

b - LABELING:

- MEETS PACKAGING SPECS AS PER GS-14-920

c - LEGAL STATEMENT: SEE GS-22-008

THE PRODUCT IS NOT INTENDED TO BE EXPOSED TO A MANUFACTURING SOLDER PROCESS.

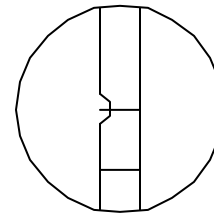
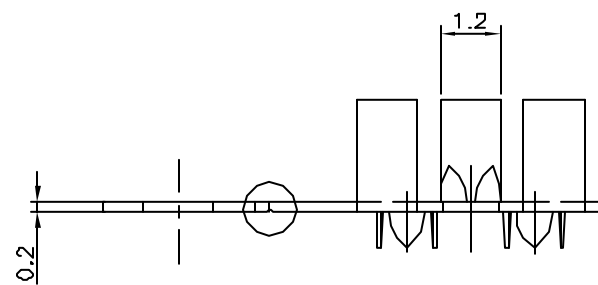

SCALE 40/1

73396-40XLF	1-5µm Sn MIN OVER 1.27µm Ni MIN
73396-40X	1-5µm SnPb MIN OVER 0.1µm Ni MIN
PRODUCT NUMBER	PLATING

mat'l. code	surface	tolerance	projection	product family
SEE NOTES	ISD B12 ✓	ISO 406 ISO 111		STAR CRIMP
tr e ch no dr date	tolerances unless otherwise specified	angled linear	mm	title
A F901B4 DLE 99.03.19		±0.13		STAR CRIMP
B F10722 JMP 01.12.04			scale 10:1	FOIL-WIRE CLINCHER
C F04-0373 DLE 04.11.19	±2°			dwg no
D F05-0284 DLE 05.11.07	dr	D LEGRAND	98.08.18	sheet 1 of 1
E F06.0214 DLE 06.06.30	enfr	JM PHAMVAN	98.06.18	size
F F07-0128 DLE 07.02.08	chr	D LEGRAND	98.08.18	A2
G F07-0282 PNZ 07.12.03	app	JM. PHAMVAN	98.06.18	type
sheet index	revision			CUSTOMER Drawing
sheet	sheet			